

SPECIFICATION	VALUE
NO. of PHASES	3
NO. of POLES	4
RATED VOLTAGE(V)	24
RATED CURRENT(A)	$0.98\pm10\%$
RATED POWER(W)	15
RATED SPEED(RPM)	$5000\pm10\%$
RATED TORQUE(mN.m)	29
NO LOAD CURRENT(A)	0.18
NO LOAD SPEED(RPM)	7400
SENSOR	HALL SENSOR
INSULATION CLASS	CLASS B
INSULATION RESISTANCE	100M Ω MIN @ 500VDC
DIELECTRIC STRENGTH TEST	500VAC for 1 MINUTE
BEARING TYPE	NMB BALL BEARING, C3

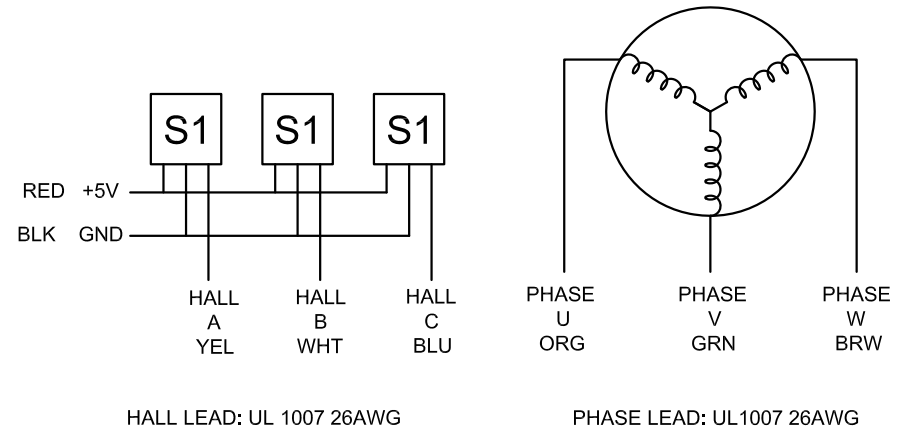

	APVD		
	CHKD		
1.5:1	DRN		
SCALE	SIGNATURE	DATE	

BRUSHLESS DC MOTOR

36BLR50-24-01